

MANSION HUNGARIAN POINT DRYBACK

INSTALLATION MANUAL

IMPORTANT INFORMATION

Please contact the point of sale if you are unsure about any part of the installation and maintenance instructions or the warranty terms.

Solidfloor Dryback is a flexible PVC flooring that feels soft and warm underfoot. The floors are sound-absorbing and 100% water-resistant. Solidfloor Dryback is specially designed for fully glued installation to the subfloor using adhesive.

Installation with PVC adhesive

- ▶ The subfloor must be professionally leveled. See the 'Subfloor' paragraph for the standards for this.
- ▶ For spaces larger than 150m² or longer than 25 m, expansion joints (at least 1 cm wide) should be used. Expansion joints can be neatly covered with expansion profiles.



GENERAL REQUIREMENTS

- Tape
- Utility knife
- Ruler
- Optionally: Sealant (with caulking gun) + caulking supplies
- Dryback adhesive
- Trowel
- Roller weighing at least 50kg (this can be rented if needed)

General

- Allow the floor to acclimate in the packaging for a minimum of 48 hours in the room where it will be installed.
- During and after installation, maintain the room temperature between 18 and 27°C. The relative humidity should be between 40 and 65%.
- These floors are not suitable for outdoor installation or in areas that are consistently wet (saunas, swimming pools, and/or shower floors).
- There should be a minimum of 2.5mm expansion gap around all walls or fixed elements (pillars, kitchen units, or baths) to allow for floor movement.
- Never install heavy, permanent, or structural elements such as kitchen islands or stairs on top of the floor.
- Check the floorboards for any defects or damage, as warranties only apply to hidden defects. If in doubt, contact the point of sale.

Subfloor

Proper preparation of the subfloor is essential for achieving the desired result. The subfloor should be hard, completely level, clean, structurally sound, free from cracks, and consistently dry (for concrete, maximum 2% moisture content). Additionally, the subfloor should be free from remnants of plaster, adhesive, paint, or other irregularities to prevent telegraphing. For concrete subfloors, they should be hard, completely level, and dry to prevent telegraphing. The subfloor should have a surface regularity that meets the SR1 standard (3 mm in 2 m reference BS8203).

Moisture in subfloors

If the residual moisture in the screed exceeds the prescribed values, regardless of whether the floors are old or new, a surface moisture barrier (SMB) should be installed. Always use a reliable construction moisture meter. The maximum allowable residual moisture is 2% for concrete screeds and 0.3% for calcium sulfate (anhydrite) screeds.

Scan for more information about Solidfloor



STURDY SUBFLOORS: CONCRETE / SAND-CEMENT SCREEDS

New and old

For all concrete floors, mechanically sand the floor to remove contaminants (cement slurry, paint, plaster, adhesive, etc.), prime the floor, and then apply a compatible leveling compound with a minimum thickness of 3 mm. If a moisture barrier (DPM) needs to be installed, it should already be in place before applying the primer and leveling compound.

Polished concrete floor

Polished concrete floors should be sanded before applying a layer of primer. Sanding can be done using milling or light sandblasting techniques. Floors should also be sanded when installing a moisture barrier (DPM). The sanding should be done before the moisture barrier (DPM) can be installed. Next, the floor should be primed before applying a compatible leveling compound (minimum 3 mm thick).

'Anhydrite' (calcium sulfate screed)

Anhydrite screeds can sometimes be difficult to recognize and may be mistaken for more traditional cement-based products. If the screed is not dry enough, consult the manufacturer and ensure that the appropriate leveling compound is selected.

Painted Floors

Mechanically remove all paint back to the original base floor, prime the floor, and apply a compatible leveling compound with a minimum thickness of 3 mm.

Stone Tile / Mosaic / Terrazzo / Ceramic

Check if the floor is free from signs of moisture (e.g., color variations, irregularities). Use a reliable moisture meter to exclude moisture. If moisture is detected after testing, consult your supplier. Inspect the floor surface for unstable, loose, and broken tiles. Remove loose particles and fill deep holes with quick-drying concrete. Degrease, rinse, and sand the surface of the floor. Apply a primer and a compatible leveling compound with a minimum thickness of 3 mm. A second layer of primer and leveling compound may be required to smooth out old tile grout lines.

WOODEN SUBFLOORS: STANDARD

(floorboards / Tongue and Groove / Chipboard / MDF / OSB)

Floorboards should be securely fastened, loose planks should be tightly secured, and worn/damaged planks should be replaced. The floor should be leveled with plywood sheets or other suitable sheet materials. Screw or nail the plywood sheets to the subfloor with a maximum spacing of 150 mm. Joints should be smoothed with a filler or alternatively, a complete layer of fiber-reinforced leveling compound.

Wavy Wooden Floors

These floors are not suitable for dryback floors.

OTHER EXISTING SUBFLOORS:

- RESILIENT FLOORS

(e.g., linoleum, PVC, thermoplastic, carpet, cork, laminate)

Remove existing floors and any traces of adhesive residues. Then treat the floor as prescribed in the previous chapter.

FLOOR HEATING

The floor may only be installed on warm water underfloor heating. The surface temperature should not exceed 27°C. If this cannot be guaranteed, a two-component adhesive must be used for installation.

Note: If the underfloor heating is turned off after installation (or accidentally shuts off due to an automatic function or overnight), gaps and cracks may appear. Depending on the indoor climate, a dispersion adhesive will be fully cured within 72 hours. During this period, the thermoplastic-activated floor should not cool down, as the elements will contract linearly and remain permanently adhered in this smaller form.

For cooling systems, the system should have a condensation safeguard, ensuring that the water in the floor pipes does not differ by more than 3°C from the room temperature. This instruction applies only to warm water-based underfloor heating and underfloor heating with cooling, provided that a condensation safeguard is installed. Installation on electric underfloor heating is not allowed. PVC Dryback should not be installed on underfloor heating systems installed before 1990, as these systems generally produce higher temperatures.

If you have doubts about the subfloor, do not proceed with the installation and contact your point of sale for further advice. The final result heavily depends on the conditions under which the floorboards are installed.

INSTALLATION WITH DRYBACK ADHESIVE (1)

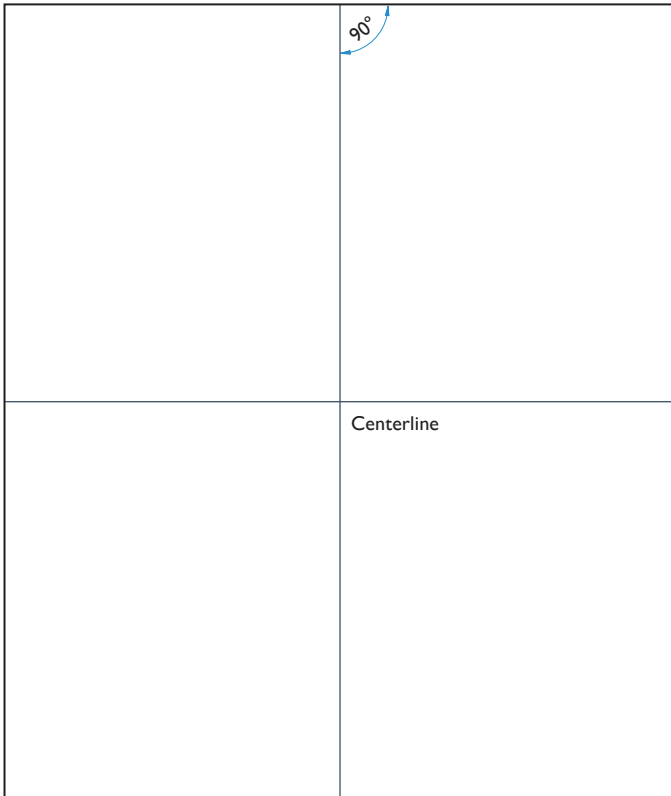

- 1 Determine the center of the room. Place a chalk line through the center and perpendicular to the wall in the length direction of the room. This is the centerline.

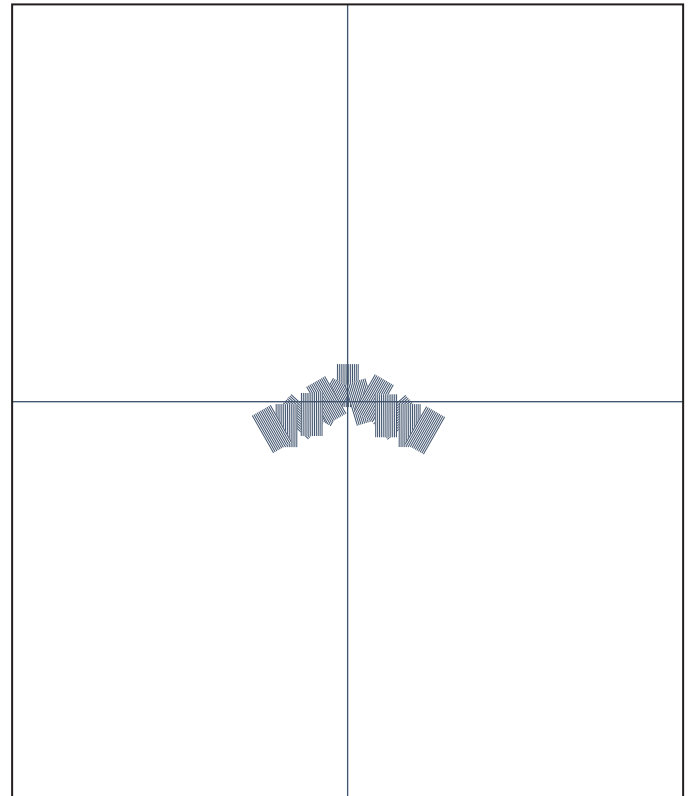

- 2 Apply enough adhesive to the center of the room with a notched trowel to bond 2 Hungarian point panels. Follow the adhesive supplier's instructions and check after some time if the adhesive has sufficient tack. If so, you can start bonding the first 2 panels.

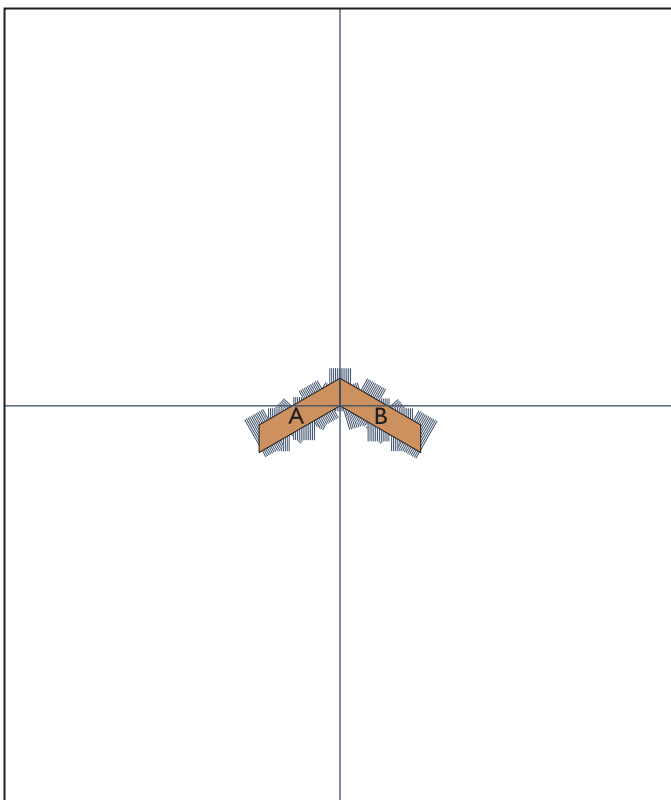

- 3 The Hungarian point floor has an A and a B panel. Place an A and B panel against the centerline and ensure they seamlessly connect.

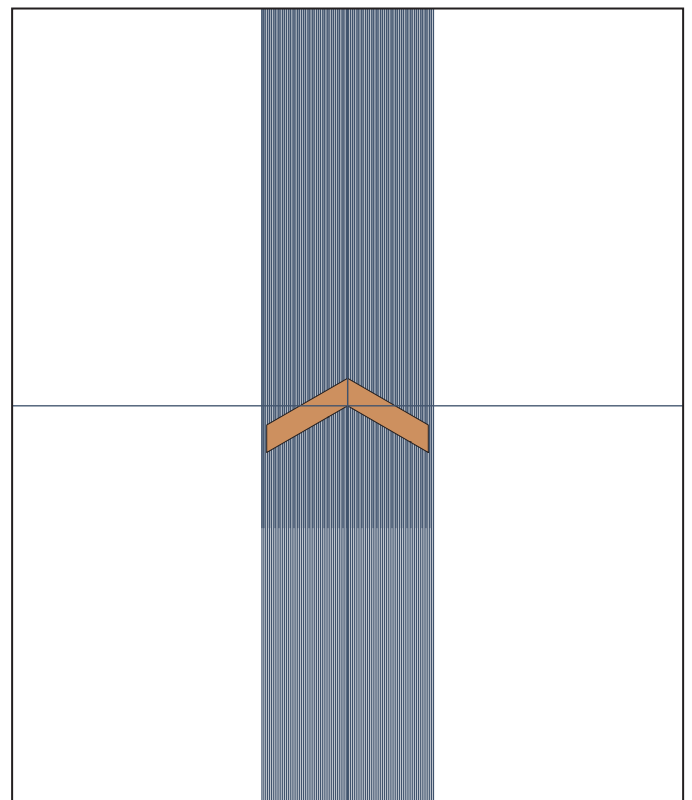

- 4 Once the first 2 panels are securely in place, the rest of the row can be set in adhesive according to the adhesive manufacturer's guidelines. Check if the adhesive has enough tack before proceeding with placing the remaining panels.

INSTALLATION WITH DRYBACK ADHESIVE (2)

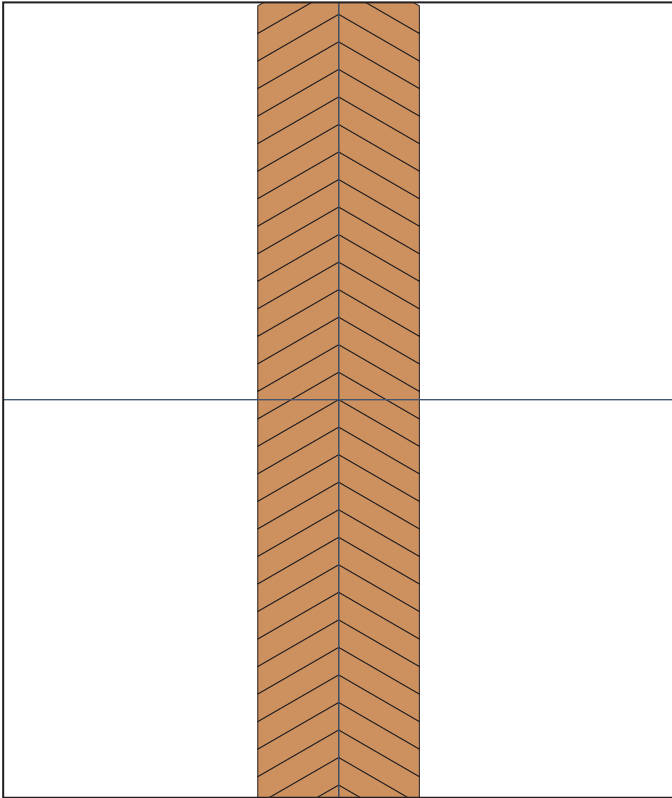

- 5 Complete a full row. Ensure panels are snugly placed against each other and that there are no gaps or differences between panels.

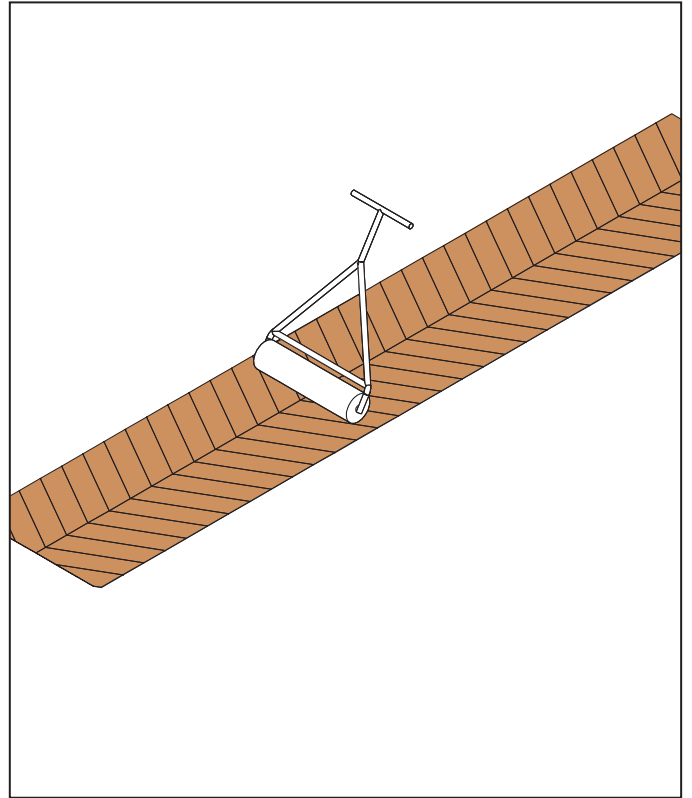

- 6 Before starting a new row, roll the newly laid panels with a roller weighing at least 50 kg. Repeat this after 30 minutes.

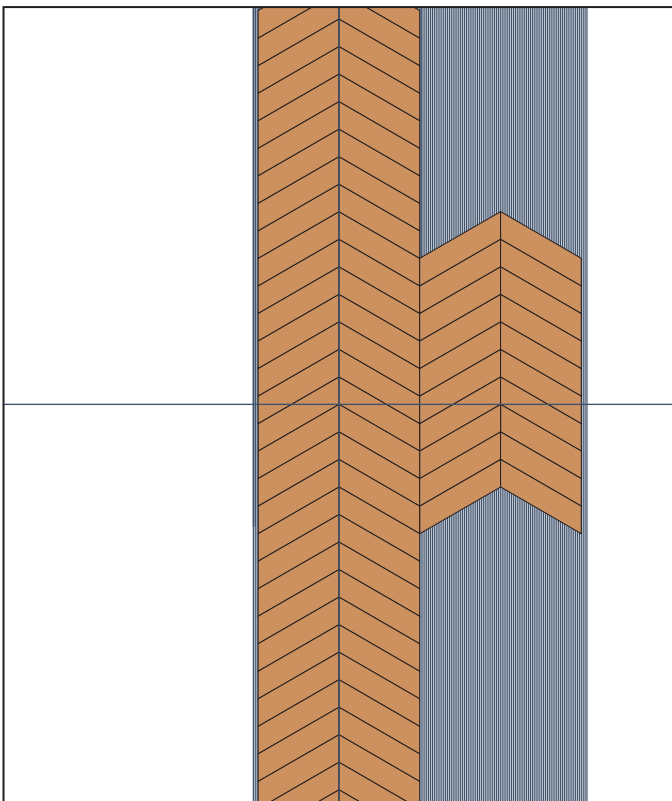

- 7 Subsequently, lay the next rows in the same manner until the entire floor is laid.

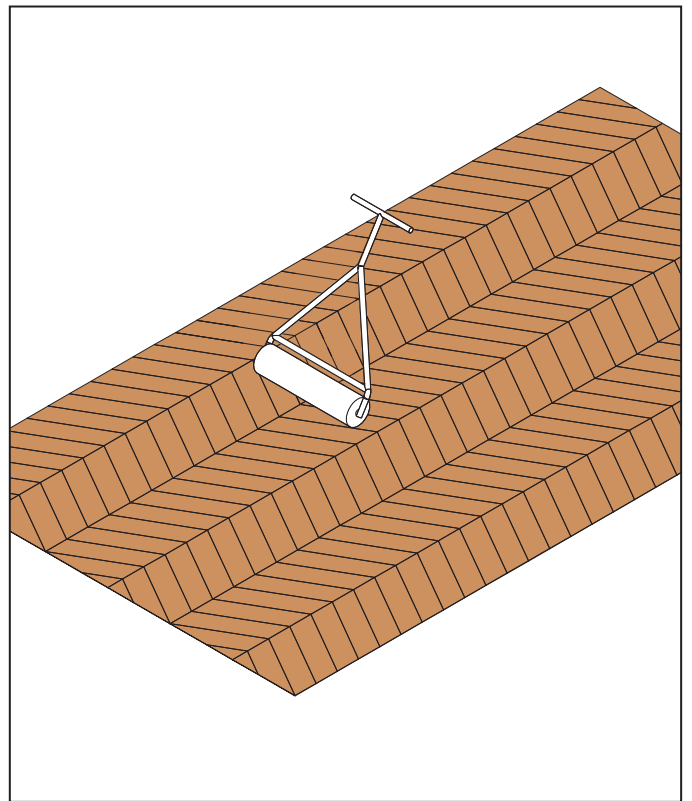

- 8 Roll the entire floor in all directions after laying.

SPECIAL FEATURES AND FINISHING

Removing glue residues (when installing with PVC adhesive)

Never use solvents to remove glue stains. Remove glue stains immediately with a damp cloth. Soak dried adhesive stains loose with hot water and remove with a soft brush or damp cloth.

Humid areas

In damp environments, we recommend sealing the floor at connections to walls and sanitary fixtures with polyurethane sealant. Please note that this floor cannot be used as a shower floor.

Finishing

Finish the edges with a neat baseboard. After installation with the self-adhesive underlay, the floor can be walked on and loaded after 24 hours. The same applies to installation with PVC adhesive. If a different adhesive has been used, please follow the instructions provided for that adhesive.

MAINTENANCE

Just like everything you use on a daily basis, a floor you live on also needs maintenance. Fortunately, Solidfloor Dryback is very easy to maintain, making it simple to keep clean. Solidfloor has developed 2 different products specifically for its floors.

Easy Clean

When it's time for a thorough cleaning and you want to give your floor an intensive cleanse, use Solidfloor Easy Clean. Always read the instructions before use.

Easy Protect

After an intensive cleaning, use Solidfloor Easy Protect to give your floor a durable protective layer, so it can withstand wear and tear for a longer period.

TERMS AND CONDITIONS

Preventive Tips

Prolonged exposure to direct sunlight can damage your floor. Use curtains to minimize direct sunlight. Use a good doormat to prevent moisture and dirt from being tracked inside. Avoid rubber floor mats and black furniture caps. Use high-quality felt pads on chair legs and other furniture to protect the floor, and avoid dragging heavy objects across the floor. If using furniture with wheels, ensure that the wheels are suitable for a flat vinyl flooring surface (no rubber). Placing a floor mat under office chairs is recommended to prevent damage.

WARRANTY TERMS AND CONDITIONS

This floor has been produced with care. In the event of hidden material and/or production defects occurring within the specified period after the date of purchase, the following warranty conditions apply:

- If you notice visible defects in the product after opening the packaging, you must report this to your point of purchase before installation.
- Defects and cannot exceed the value of the delivered material. Parts with visible defects should not be installed. Damages will be considered with economic depreciation taken into account. The residual value will be determined based on the remaining warranty period of your floor.
- Warranty claims can only be made with the presentation of the invoice or purchase receipt.
- You can find the complete warranty conditions of Solidfloor on the website.

If you have any questions, please contact your point of purchase.

Warranty voids:

- Damages due to wear, damages, and tears on the wear surface caused by improper use, falling objects, sand ingress, and/or usage of sharp tools.
- Rough and/or improper use.
- Any other careless use of the product.
- If a defect in the product could already be determined before installation.
- Usage of the material or application in unsuitable spaces.
- Installation on unsuitable subfloors or climatic conditions other than specified in these installation instructions.

These warranty conditions do not affect your statutory rights and obligations. Usage class 23/33 (intensive residential use and intensive commercial use).



Solidfloor

Abram Dudok van Heelstraat 4
1096BE Amsterdam
www.solidfloor.com

 www.facebook.com/solidfloor.nl

 www.pinterest.com/floortjesol

 www.instagram.com/solid.floor